

XT series General Purpose VRLA batteries are designed with AGM(Absorbent Glass Mat) technology. XT series offers 5 years( $\leq 20Ah$ ) and 10 years( $\geq 20Ah$ ) full maintenance free design life. With a compact design and good reliability, this series is highly suited for security and alarm systems, UPS systems, emergency light systems and other small backup applications.



**Complied standards**  
 • IEC 60896-21/22  
 • JIS C8704  
 • GB/T19639

**Features and Benefits**

- Wide operating temperature range from -15°C to 50°C
- Can be used at vertical or horizontal orientation
- Balanced design for both floating and cyclic operation
- Maintenance-free operation
- Low self-discharge rate and long shelf life

**Applications**

- Alarm systems
- Communication Equipments
- Control equipments
- Security systems
- Medica Equipments
- UPS systems
- Power tools
- Toys
- Emergency Power Systems
- Photovoltaic Systems
- Security Systems

**Technical Specifications**

Nominal Voltage.....	6V (3 cells per unit)
Nominal Capacity(20°C)	
20hour rate(0.5A,5.4V).....	10Ah
10hour rate(0.95A,5.4V).....	9.5Ah
5hour rate(1.78A,5.25V).....	8.9Ah
1hour rate(6.66A,4.8V).....	6.66Ah
Dimension(mm).....	L151 x W50 x H94 x TH100mm
Approx. Weight .....	1.6kg
Terminal Type.....	F2
Internal Resistance.....	14mΩ(fully Charged @20°C)
Max.Charge Current.....	3.0A
Max.Discharge Current (5s).....	150A
Ambient Temperature	
Discharge.....	-15-45°C
Charge.....	-15-45°C
Storage.....	-15-45°C
Capacity Affected by Temp.(10 hr capacity)	
105% @40°C	
100% @25°C	
85% @0°C	
65% @-15°C	
Self-Discharge @20°C.....	Approx. 3% per month
Charge Voltage @20~25°C	
Float charge voltage.....	6.8V-6.9V
Equalize Charge Voltage.....	7.2V-7.5V

**Dimensions**

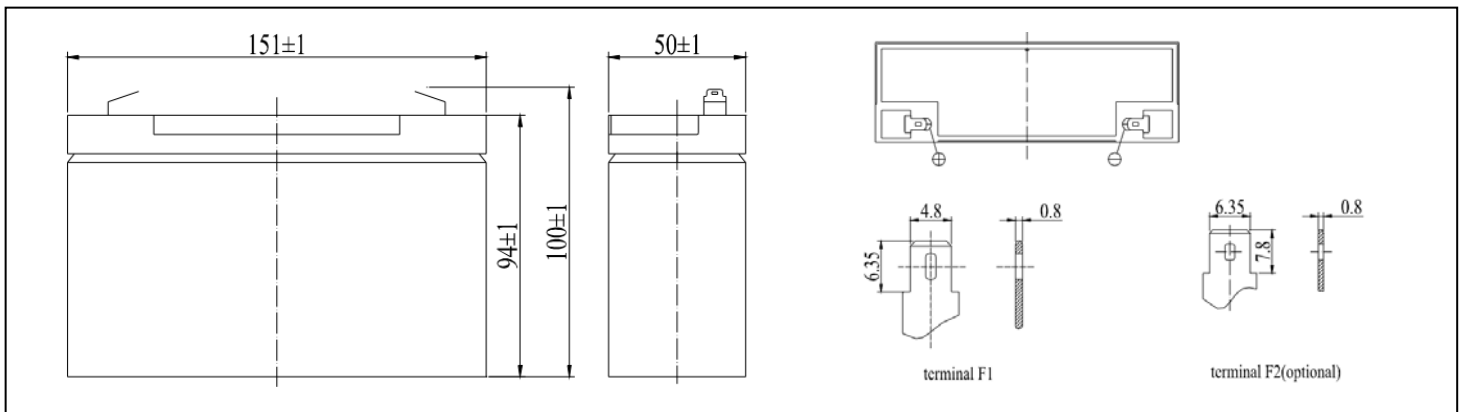

Performance Characteristics

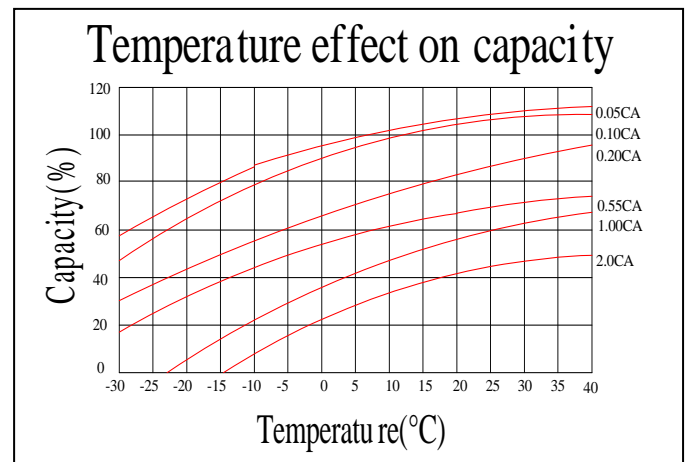
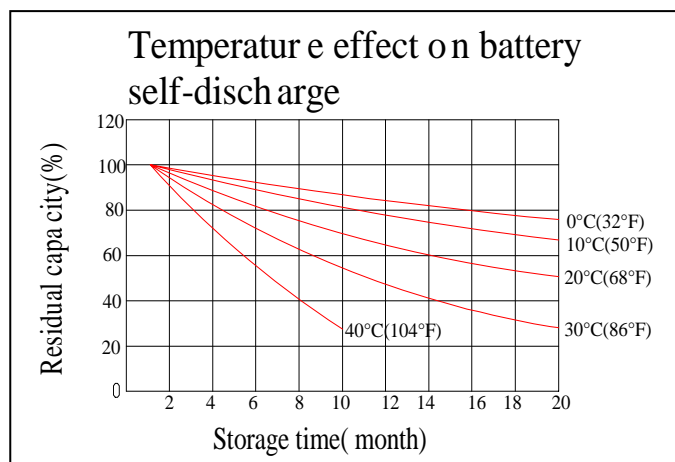
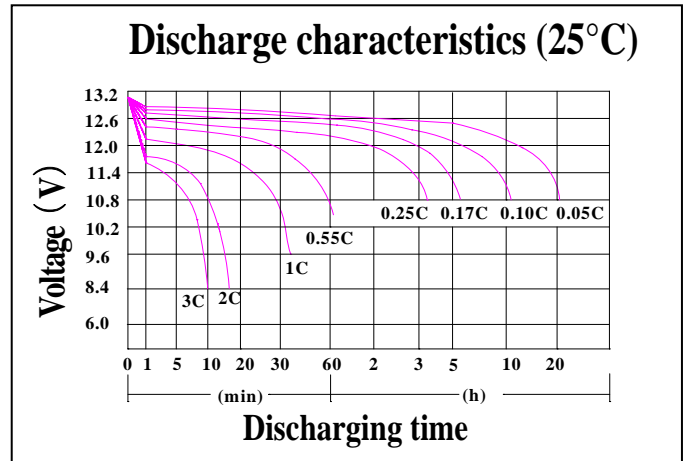
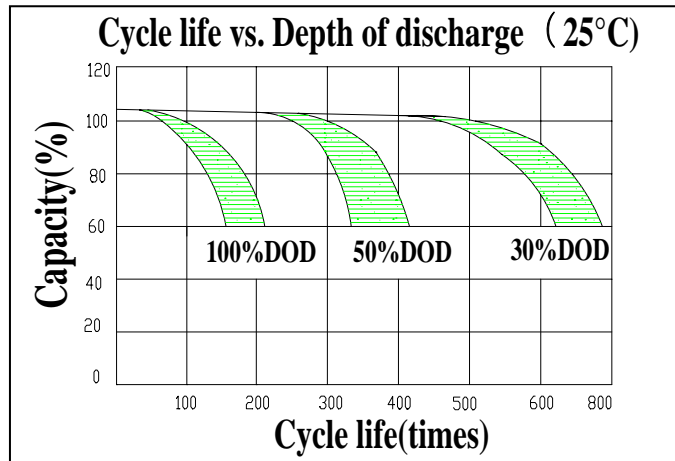
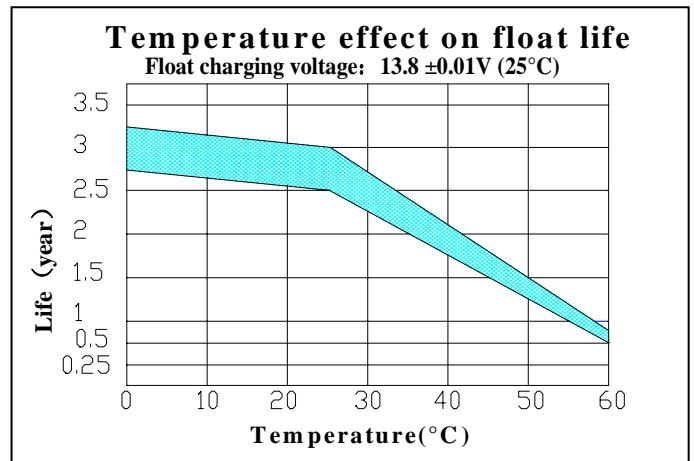
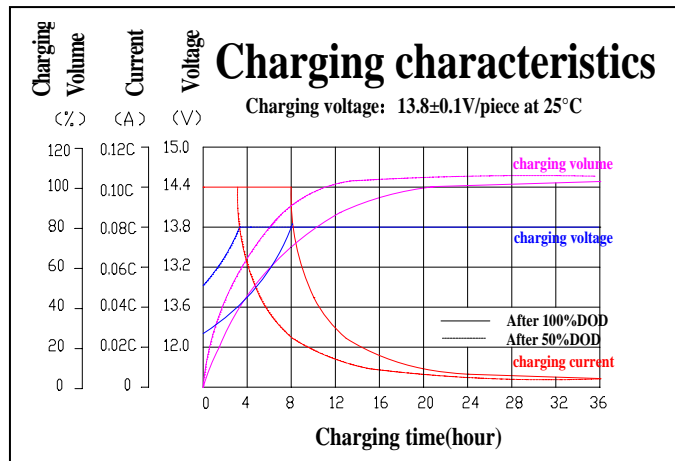

**Battery Discharge**

Discharge Constant Current per Cell (Amperes at 25°C)

F.V/Time	5min	10min	15min	30min	45min	1h	2h	3h	5h	8h	10h	20h
1.60V	34.1	22.0	16.6	11.0	7.70	6.66	4.13	2.83	1.88	1.27	1.05	0.55
1.65V	33.5	21.6	16.3	10.8	7.56	6.53	4.05	2.78	1.85	1.24	1.03	0.54
1.70V	32.9	21.2	16.0	10.6	7.42	6.41	3.98	2.72	1.82	1.22	1.01	0.53
1.75V	32.2	20.8	15.7	10.4	7.28	6.29	3.90	2.67	1.78	1.20	0.99	0.52
1.80V	31.0	20.0	15.0	10.0	7.00	6.05	3.75	2.57	1.71	1.15	0.95	0.50

Discharge Constant Power per Cell (Watts at 25°C)

F.V/Time	5min	10min	15min	30min	45min	1h	2h	3h	5h	8h	10h	20h
1.60V	65.6	42.4	31.9	21.2	14.8	12.8	7.94	5.44	3.63	2.44	2.02	1.06
1.65V	64.4	41.6	31.3	20.8	14.6	12.6	7.80	5.34	3.56	2.39	1.98	1.04
1.70V	63.3	40.8	30.7	20.4	14.3	12.3	7.65	5.24	3.50	2.35	1.94	1.02
1.75V	62.1	40.0	30.1	20.0	14.0	12.1	7.51	5.15	3.43	2.31	1.91	1.00
1.80V	59.7	38.5	29.0	19.3	13.5	11.6	7.22	4.95	3.30	2.22	1.83	0.96

(Note) The above characteristics data are average values obtained within three charge/discharge cycle not the minimum values.

**Battery Construction**

Component	Positive plate	Negative plate	Container & Cover	Safety valve	Terminal	Separator	Electrolyte	Pillar seal
Features	Thick high Sn low Ca grid with special paste	Balanced Pb-Ca grid for improved recombination efficiency	ABS (UL94-V0 optional)	Flame Si-Rubber and aging resistance	Copper No.187 (No.250 optional)	Advanced AGM separator for high pressure cell design	Dilute high purity sulphuric acid	Two layers epoxy resin seal